

BOSE[®]

802[®]-II, 802W-II, 802C SYSTEM CONTROLLER, 302[™] TANDEM-TUNED[™] BASS SYSTEM

802-II	802W-II
802C SYSTEM CONTROLLER*	302 TANDEM-TUNED [™] BASS SYSTEM

*Note: All information concerning the 802-C Controller in this manual pertains to units with serial grouping in the 100000 range. For further information on the newer SMD versions (Serial number 2000000 range) refer to the 802-C Controller Supplement: Bose P/N 129292.

SPECIFICATIONS

802 SERIES II AND 802W SERIES II LOUDSPEAKERS

Transducer Complement:	Eight (8) 4½" (11.4 cm) BOSE ^R D-11B full-range drivers.
Nominal Impedance:	8 ohms
Sensitivity: (Single Spkr)	99 dB SPL (1 watt, 1m, 300Hz-3kHz) 92 dB SPL (1 watt, 1m, 50Hz-16kHz)
Sensitivity: (Stacked Pair)	102 dB SPL (1 watt, 1m, 300Hz-3kHz) 95 dB SPL (1 watt, 1m, 50Hz-16 kHz)
Usable Frequency Range:	50Hz-16kHz
Power Handling:	240 watts continuous pink noise (50Hz-16kHz)
Maximum Power:	320 watts (rms) maximum recommended amplifier size per speaker.
Horizontal Beamwidth:	120°
Vertical Beamwidth:	100° (Single Speaker) 80° (Stacked Pair)
Input Connections <u>802-II</u> :	Two (2) parallel-wired ¼" phone jacks (6.3 mm) Two (2) parallel-wired male XLR connectors
Input Connections <u>802-IIW</u> :	Rear-panel barrier strip screw terminals
Fusing <u>802-II</u> :	Replaceable 3-ampere, quick-acting.
Fusing <u>802-IIW</u> :	External 3-ampere, quick-acting recommended in most applications.
Enclosure <u>802-II</u> :	Mica-reinforced polyethylene copolymer structural foam.
Enclosure <u>802-IIW</u> :	Acrylic-coated, walnut-grain vinyl laminate on particle board.
Dimensions <u>802-II</u> :	13 1/2" H x 20 1/2" W x 13" D (34 x 52 x 33 cm)
Dimensions <u>802-IIW</u> :	13" H x 20 1/2" W x 12 5/8" D (33 x 52 x 32 cm)
Weight <u>802-II</u> :	31 lbs. (14 kg)
Weight <u>802-IIW</u> :	38 lbs. (17 kg)

302 TANDEM-TUNED™ BASS SYSTEM

Transducer Complement:	Two (2) 12" (30 cm) BOSE ^R LF-88A Low-Frequency Transducers.
Nominal Impedance:	4 ohms
Sensitivity:	96 dB SPL (1 watt, 1m, 55-180 Hz)
Maximum Acoustic Output:	121 dB SPL (1m, 400W input)
Dispersion:	180°

302 TANDEM-TUNED™ BASS SYSTEM

Power Handling:	200 watts white noise as per EIA Standard RS-426-A.
Maximum Power:	400 watts (rms) maximum recommended amplifier size per speaker.
Crossover Frequency:	180 Hz
Input Connections:	One (1) ¼" phone jack (6.3 mm) One (1) male XLR connector
Output Connections:	Two (2) ¼" phone jacks (6.3 mm)
Fusing:	Replaceable 7-ampere, quick-acting.
Enclosure Construction:	Impregnated resin board.
Dimensions:	32" H x 23" W x 16" D (81 x 58 x 41 cm)
Weight:	115 lbs. (52 kg)

802-C SYSTEM CONTROLLER*

Input Connections: (per channel)	One (1) low-Z balanced female XLR connector One (1) high-Z unbalanced ¼" phone jack (6.3 mm)
Output Connections: (per channel)	Two (2) ¼" phone jacks (6.3 mm) (outputs used depend on mode of operation)
Input Impedance:	Balanced input, 4 k ohms Unbalanced input, 42 k ohms
Electronic Crossover Frequency:	180 Hz (bi-amplified mode only)
Maximum Output Level:	4 Volts (+12dB into 600 ohms (50Hz-16kHz) 8 Volts (+18dB into 10k ohms (50Hz-16kHz)
Total Harmonic Distortion:	Less than .02% at 1 Volt (0 dBV) Less than .2% at 8 Volts (18 dBV)
Output Noise:	Less than 20uV (-94 dBV) A-Weighted
Power Requirements:	120 Vac, 50-60 Hz, 3.5 watts 220 Vac, 50-60 Hz (Not available in USA) 100 Vac, 50-60 Hz (Japan only)
Dimensions:	1 3/4" H x 10" W x 5" D (4.4 x 25.4 x 12.7 cm)
Weight:	1.97 lbs (.895 kg)

* Note: All information in this manual concerning the 802-C Controller pertains to units with serial numbers in the 100000 range. For further information on the newer SMD versions (serial number 2000000 range) refer to the 802-C Controller Supplement: Bose P/N 129292.

TECHNICAL DESCRIPTIONS

802 Series II and 802W Series II

The BOSE^R 802-II and 802W-II Articulated Array^R systems are full-range equalized loudspeakers designed for high-quality reinforcement of voices and music. The 802-II speaker is ideal for applications requiring a rugged, portable enclosure, while the 802W-II speaker is intended for use in permanent indoor sound system installations. The acoustic properties of the 802-II and 802W-II systems are identical.

Both speakers employ eight (8) 4½" (11.4 cm) BOSE^R D-11B full-range drivers, mounted symmetrically in vertical pairs on a faceted Articulated Array baffle assembly. The drivers feature low-impedance, edge-wound aluminium voice coils, 12-ounce Ferrite V ceramic magnets, molded polyester frames and advanced cone and motor systems for high linear excursion and power output capabilities.

Tuned Reactive Air Columns reduce distortion by controlling the cone excursion required to reproduce deep bass frequencies. A built-in Directivity Control circuit (see Fig. 1) maintains the vertical dispersion pattern through the high-frequency range and also protects the drivers from the effects of high-frequency overload.

The 802-II speaker enclosure is composed of polyethylene copolymer structural foam, reinforced with 10% mica for improved durability and impact strength.

The 802W-II speaker enclosure is laminated with an acrylic-coated walnut-grained vinyl that can be painted to match special color requirements. The complete 802W-II baffle assembly can be easily removed from the wood cabinet to facilitate the installation of mounting hardware.

802-C System Controller

The 802-C System Controller is a sophisticated signal processing device which combines the functions of the three equalizers, an automatic switching circuit, and an electronic crossover. The 802-C automatically selects the proper crossover function and

equalization curve for a given system application through use of a switching network operating in conjunction with the unit's output jacks. In addition to signal routing based on equalization requirements, the switching network indicates mode of operation on its front panel. Also included on the front panel are high-cut and low-cut switches which decrease the line output by 4dB at 55Hz and by 10dB at 16kHz. Sharp subsonic and ultrasonic band-limiting filters reduce power waste, stage noise, high-frequency instability, and interference. The 802-C fits into one space of a standard 19" equipment rack with the optional RMK-8 Rack Mount Kit.

302 Tandem-TunedTM Bass System

The 302 Tandem-Tuned Bass System incorporates an innovative transducer loading system that takes full advantage of the energy being radiated by both the front and rear of the transducer. Each of the two (2) 12" (30cm) LF-88-A low-frequency transducers is loaded by two subenclosures of different volumes, resulting in two tunings for the system, 55Hz and 110Hz. The resulting response is smooth throughout the passband of the speaker.

In the passive mode of operation, the internal crossover of the 302 system automatically presents proper impedance to the amplifier. This impedance is maintained when the unit is used alone or with one or two 802 speakers.

The 302 cabinet is constructed of impregnated resin board with uniformity characteristics superior to those of particle board or plywood. Corners are molded for stacking, and recessed handles are built into the sides of the cabinet. Stacking grooves on the cabinet top accept the matching ridges which are molded into all BOSE 802 speakers.

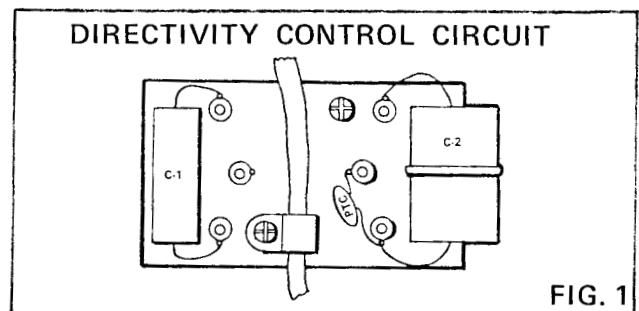

FIG. 1

802-II AND 802W-II LOUDSPEAKER TEST PROCEDURE

GRILLE REMOVAL:

For ease of determining problem areas of the 802-II and 802W-II loudspeaker, it is recommended that the grille be removed for testing purposes. To remove the grille, unscrew the two large clinch nuts on the Reactive Air Columns by rotating them counterclockwise. Then, remove the grille retainer and lift the grille off the speaker and set it aside. (See Fig. 2).

DRIVER LOCATION:

Knowing the location of the eight drivers in the 802-II and 802W-II loudspeakers is essential in troubleshooting the speaker (see the Troubleshooting Guide on next page). To find the driver location, set the speaker upright in reference to the input terminals. With the print on the Terminal section reading correctly (not upside down), the driver location is as shown in Fig. 3.

DIRECTIVITY CONTROL CIRCUIT:

This circuit effects the dispersion pattern of the 802-II and 802W-II speakers. If a speaker is brought in for ANY complaint, directivity tests MUST be made to assure proper operation of the speaker. (See the Troubleshooting Guide and Fig. 4, Directivity location drawing.)

TEST:

Connect a sine wave oscillator to a power amplifier. Adjust the frequency of the oscillator to approximately 15Hz. Adjust the amplifier output to 15 volts rms and connect to the speaker input. No extraneous noises such as rubbing, scraping, or ticking should be heard, other than the normal suspension sounds. Sweep the oscillator from 15Hz to 18kHz, assuring that there are no extraneous noises present.

802-II INDIVIDUAL DRIVER TEST AND REPLACEMENT PROCEDURES

This procedure is an aid to find actual component failure after the audible test procedure has been performed.

1. Remove grille as described in Test Procedure section of this manual.

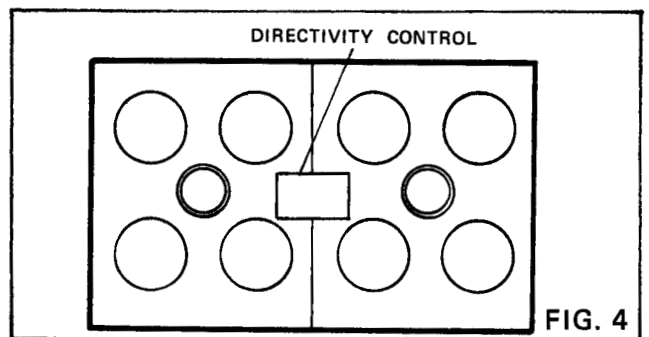
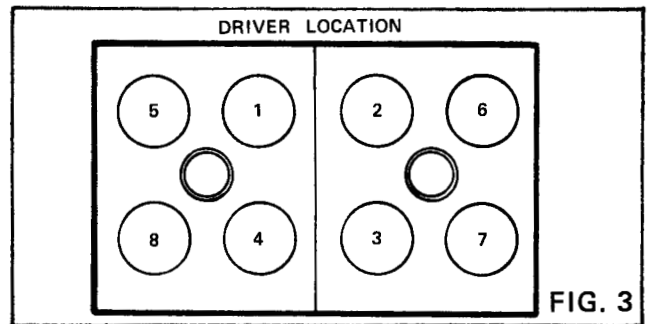
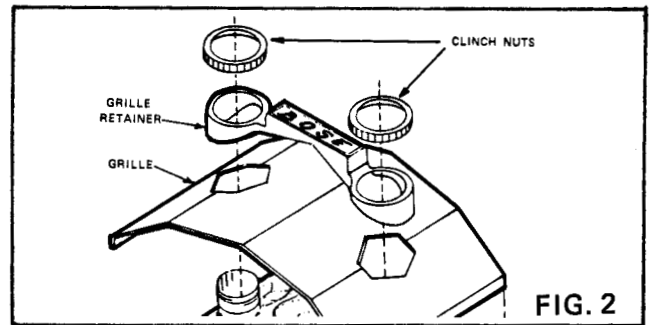

2. Remove the three (3) screws from the suspected driver and set aside.

3. Lift the suspected driver out of Articulated Array™. DO NOT disconnect the wires from the driver at this time.

4. Take an ohmmeter (such as a Triplet) and set to the 1-ohm scale. Place the meter leads across the plus (+) and minus (-) terminals of the driver to see if the cone deflects. If the driver does not deflect, the voice coil is open, and the driver must be replaced. If the driver does deflect, it is good and should be reinstalled, and the next suspected driver be removed and tested.

NOTE: This test identifies open drivers. If the driver is making rubbing or ticking noises during the audible testing, replace the driver.

5. Cut the wires connected to the driver as close to the terminals as possible. Take note as to which color wire(s) is connected to each terminal of the driver.

6. Strip the wires and reconnect to the replacement driver. If there is any question as to color or polarity, refer to the schematic diagram for the proper color codes.

7. Align the driver and gasket to the j-clips, and secure the driver with three (3) screws.

8. Perform audible testing to assure all drivers and the Directivity Control circuits are functioning properly.

9. If repair is complete, remount grille. If there is a fault with the Directivity Control Circuit, proceed to Directivity Control Component Replacement instructions below.

802-II DIRECTIVITY CONTROL COMPONENT REPLACEMENT

NOTE: The Directivity Control effects the dispersion pattern of the 802-II speaker. If an 802-II is brought in for ANY complaint,

the Directivity Control MUST be tested to assure proper operation of the speaker. (See Troubleshooting Guide).

1. Locate Drivers 1, 2, 3, and 4 (See Driver Location Drawing, Fig. 3) and perform steps 1 thru 3 of the Driver Test and Replacement procedure.

2. Move acoustic foam, and the harness wires attached to the drivers, back to expose the Directivity Control. (See Fig. 4 for location of circuit.)

3. Remove and replace the defective component.

4. Return the acoustic foam and all harness wires to their original position.

5. Align each driver and gasket to the j-clips, and secure each driver with three (3) screws.

6. Perform Test Procedure to assure proper repair and no wire buzzes have developed.

7. Remount grille.

802-II AND 802W-II TROUBLESHOOTING GUIDE

The following guide will assist you in determining fault areas. **NOTE: THIS GUIDE USES THE FOLLOWING FREQUENCIES: 15HZ, 100HZ, 10kHz.** Some of the drivers listed as inoperative are reproducing at REDUCED output.

<u>SYMPTOM</u>	<u>DEFECT</u>
1. SOUND, ALL DRIVERS AT 15HZ: SOUND, ALL DRIVERS AT 100HZ: SOUND, DRIVERS 1, 2 AT 10KHZ:	A. SPEAKER CHECKS GOOD.
2. NO SOUND, ALL FREQUENCIES:	A. OPEN FUSE (802-II ONLY) B. DRIVER 1 OR 2 OPEN (SEE FIG. 3)
3. NO SOUND, ALL DRIVERS AT 15HZ: DRIVERS 3, 4, 5, 6, INOP AT 100HZ: DRIVERS 3, 4 INOP AT 10KHZ:	A. DRIVER 3 OR 4 OPEN (SEE FIG. 3)
4. NO SOUND, ALL DRIVERS AT 15HZ: DRIVERS 5, 6, 7, 8 INOP AT 100HZ: DRIVERS 5, 6 INOP AT 10KHZ:	A. DRIVER 5 OR 6 OPEN (SEE FIG. 3)
5. NO SOUND, ALL DRIVERS AT 15HZ: DRIVERS 5, 6, 7, 8 INOP AT 100HZ: DRIVERS 7, 8 INOP AT 10KHZ:	A. DRIVER 7 OR 8 OPEN (SEE FIG. 3)
6. SOUND, ALL DRIVERS AT 15HZ: SOUND, ALL DRIVERS AT 100HZ: SOUND, DRIVERS 1, 2, 3, 4 AT 10KHZ:	A. OPEN C-1 ON DIRECTIVITY CONTROL CIRCUIT
7. SOUND, ALL DRIVERS AT 15HZ: SOUND, ALL DRIVERS AT 100HZ: SOUND, DRIVERS 1, 2, 7, 8 AT 10KHZ:	A. OPEN C-2 OR PTC ON DIRECTIVITY CONTROL CIRCUIT

802-II SCHEMATIC DIAGRAM

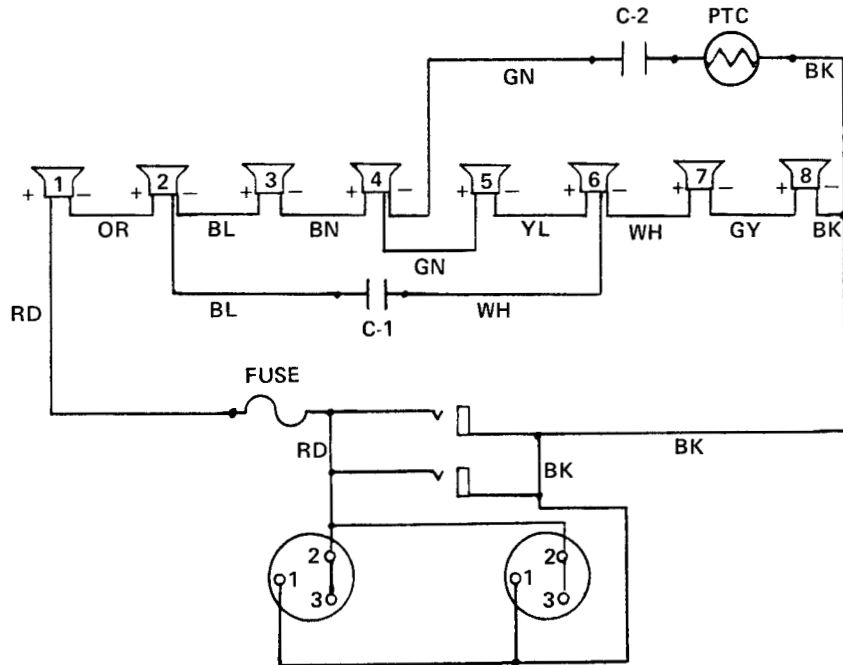

FIG. 5

802 LOUDSPEAKER INPUT PLATE PARTS LIST

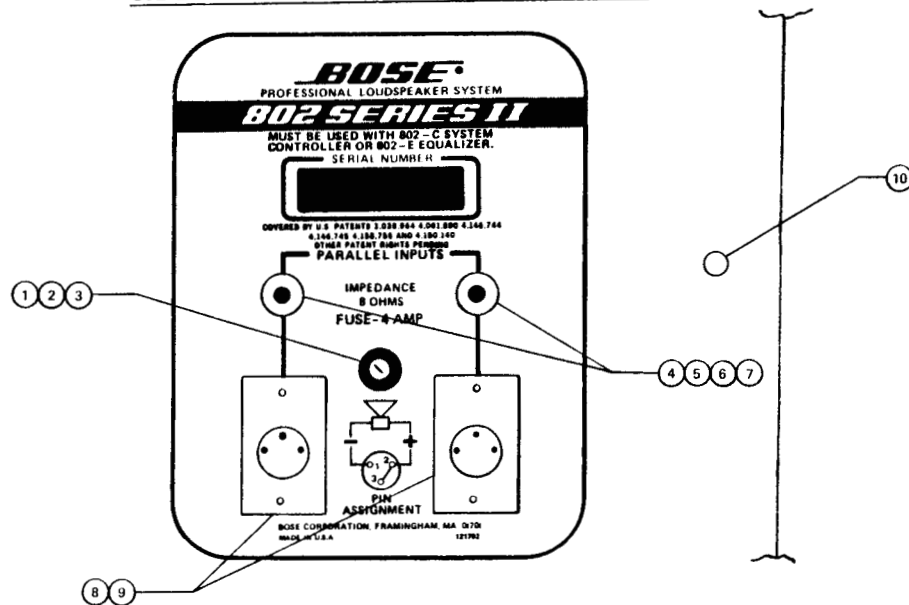

FIG. 6

Description	Part Number	Description	Part Number
①. Fuse Cap	109484	⑤. Lock Washer, Int	103294
①. Fuse Cap (Metric)	109493	⑥. Nut, Hex	100412-14
②. Fuse Holder	109485	⑦. Flat Washer	110999
③. Fuse 3AG	104715-400	⑧. Audio Connector	109486
③. Fuse 5x20mm	109492-400	⑨. Push On Fastener	109487
④. Phone Jack	102640	⑩. Pan Head Nut	121084

802 LOUDSPEAKER PARTS LIST

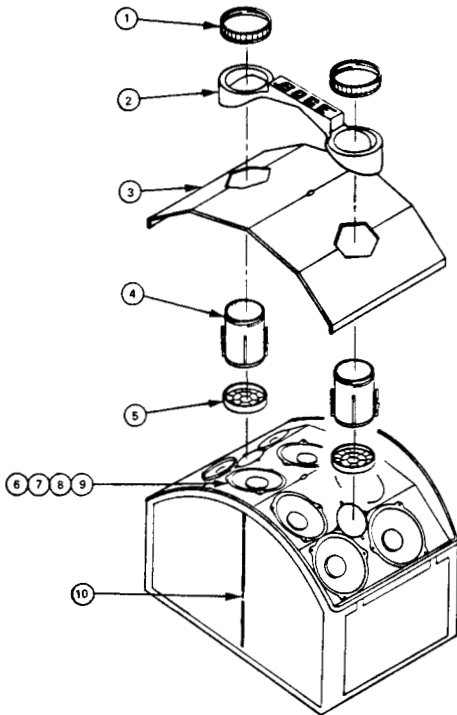

FIG. 7

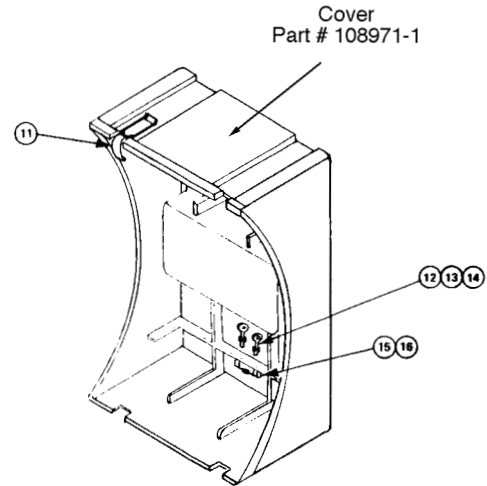

FIG. 8

<u>Description</u>	<u>Part Number</u>	<u>Description</u>	<u>Part Number</u>
①. Pinch Clinch, II	123174	⑩. Pan Head Nut	129814
②. Grille Still	121831-01	⑪. Latch	109480
③. Grille	109467-18	⑫. Thumb Screw M8	137050
④. Short Port	174164-01	⑬. Fuse Clip - 4 AG	121112
⑤. Snap Cap	174168-01	⑬. Fuse Clip (Alt)	109483
⑥. 4 1/2" Driver	121777-5	⑭. Screw #6 x .5L	103120-08
⑦. Gasket, Speaker	128407	⑮. Fuse, 3AG	104715-400
⑧. Screw #8 x .75L	103126-12	⑮. Fuse, 5 x 20mm	109492-400
⑨. Clips, J-Type	109481	⑯. Spring Clip	110167

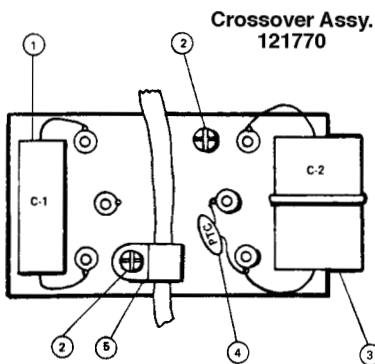

FIG. 9

802-II DIRECTIVITY CONTROL PARTS LIST

<u>Description</u>	<u>Part Number</u>
①. C-1 5 uF 10% 75V	102770
②. Screw 8 x .75L	103126-12
③. C-2 20 uF 10% 75V	119026
④. PTC Polyswitch	121247
⑤. Buss Cable Clamp	113792

802 CARTON PARTS LIST

<u>Description</u>	<u>Part Number</u>
Carton	121789
Corner Block	109477
Literature Kit	121778
Pad	109456
Owner's Manual	136073

802W-II INDIVIDUAL DRIVER TEST AND REPLACEMENT PROCEDURES

This procedure is an aid to find actual component failure after the audible test procedure has been performed.

1. Follow Steps 1 thru 9 in 802-II section, then proceed with Directivity Control Component Replacement (if necessary) as outlined below.

802W-II DIRECTIVITY CONTROL COMPONENT REPLACEMENT

NOTE: The Directivity Control effects the dispersion pattern of the 802W-II speaker. If an 802W-II is brought in for ANY complaint, the Directivity Control MUST be tested to assure proper operation of the speaker. (See Troubleshooting Guide).

NOTE: To replace any component on the 802W-II's Directivity Control Circuit, it is best to lift the Articulated Array™ out of the speaker cabinet.

1. Remove grille as described in Test Procedure section of this manual.
2. Remove the ten (10) screws that hold the Articulated Array in place. (See Fig. 10)
3. Grasp the Array by the slots on each side of the Array, and lift the entire assembly out of the enclosure. Do NOT pull on the wires.
4. Disconnect the red/black harness wires at the input terminals.
5. Locate the Directivity Control circuit, under the acoustic foam, and replace the defective component.
6. Reconnect the red/black harness wires to the input terminal. Red is positive (+) and black is negative (-).
7. Remount Array to the cabinet (DO NOT tighten screws yet) and perform testing.
8. Once repair has been confirmed, and no wire buzzes has developed, secure the ten (10) retaining screws. (Do NOT overtighten).
9. Remount Grille.

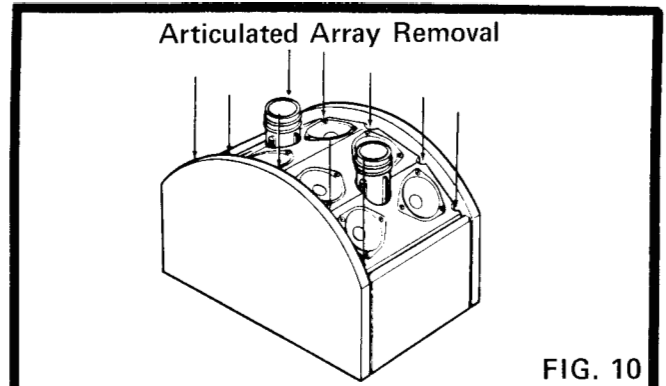

FIG. 10

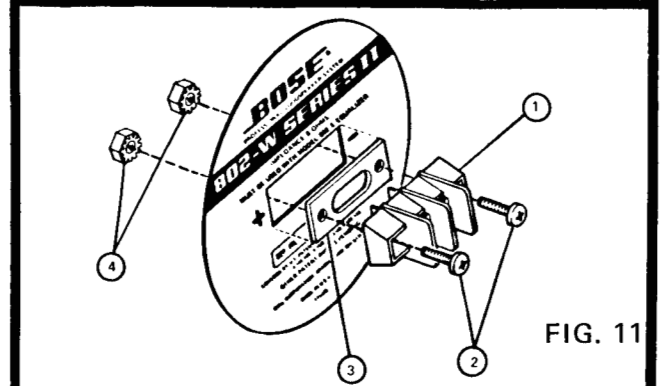

FIG. 11

802 WOOD INPUT PLATE PARTS LIST

Description	Part Number
①. Terminal Strip	130133
②. Screw Mach 6x.5L	103150-08
③. Gasket	119866
④. Kepnut #6	100413-3

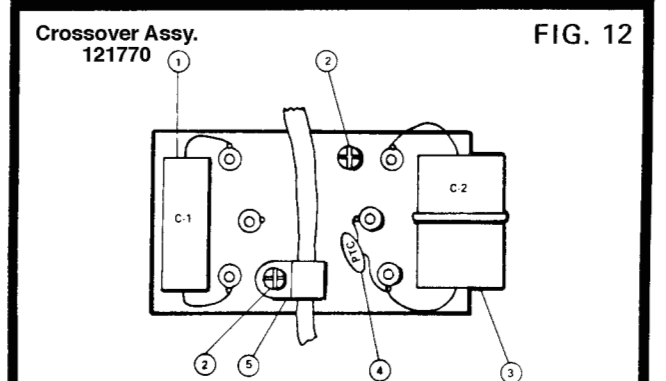

FIG. 12

PARTS LIST

Description	Part Number
①. C-1 5 uF 10% 75V	102770
②. Screw 8 x .75L	103126-12
③. C-2 20 uF 10% 75V	119026
④. PTC Polyswitch	121247
⑤. Buss Cable Clamp	113792

802W-II SCHEMATIC DIAGRAM

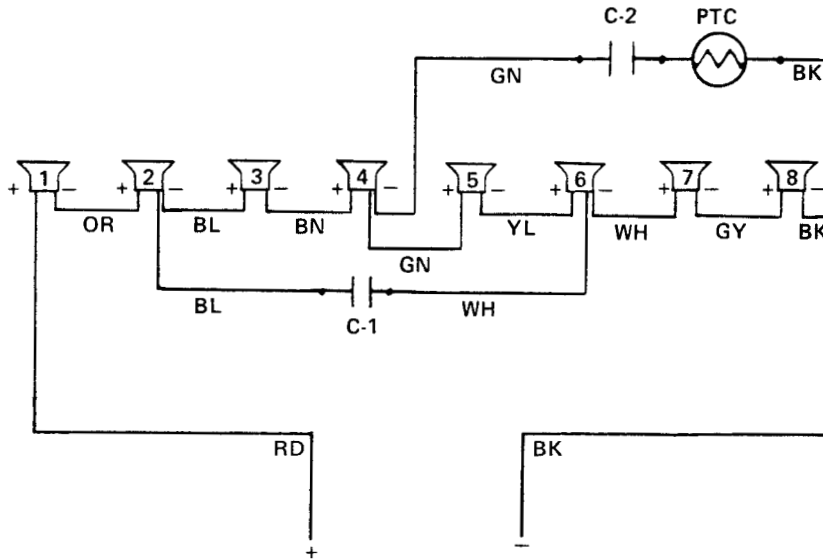

FIG. 13

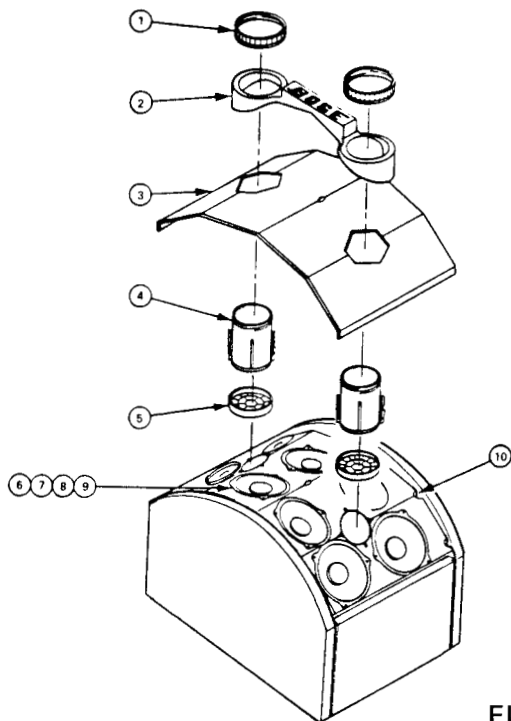

FIG. 14

802 WOOD PARTS LIST

Description	Part Number
①. Pinch Clinch, II	123174
②. Grille Still	121831-02
③. Grille	109467-18
④. Short Port	121808
⑤. Snap Cap	121807
⑥. 4 1/2" Driver	121777-5
⑦. Gasket, Speaker	128407
⑧. Screw #8 x .75L	103126-12
⑨. Clips, J-Type	109481
⑩. Screw #6-18x2"	120389-32
⑪. Twisted Pair	120386-1

802 WOOD CARTON KIT

Description	Part Number
Carton	122957
Side Filler	120784
Top/Bottom Filler	120783
Top/Bottom Pad	120785
Owner's Manual	136073
Literature Kit	130982

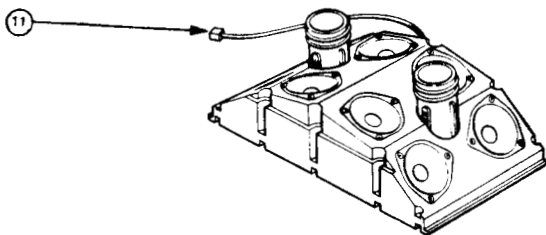

FIG. 15

302 SIGNAL TEST PROCEDURE:

Connect a sine wave oscillator to a power amplifier. Adjust the frequency of the oscillator to 15Hz. Adjust the amplifier output to 10 volts rms and connect to the input jack. No extraneous noises such as rubbing, scraping, or ticking should be heard, other than normal suspension sounds. Sweep the oscillator from 15Hz to 250Hz, assuring that no extraneous noises are present.

302 CROSSOVER TEST PROCEDURE:

Set oscillator to 200Hz and reduce the amplifier output to 2 volts rms. Place a phone jack with an 8-ohm RESISTIVE load into one of the output jacks, and measure the output voltage across the resistor: .3 to .5 volts.

Set oscillator frequency to 1kHz, and measure the output voltage across the 8-ohm resistor: 1.6 to 2.1 volts.

Repeat the same steps for the second output jack to assure BOTH crossover networks are functioning correctly.

302 PHASING CHECK:

Using a 6- to 12-volt dc power supply, check that both speakers are in phase by placing the positive portion of the supply to the tip terminal of a phone jack and the negative portion to the sleeve. Apply to the input jack of the 302. Both woofers should move outward.

302 DRIVER REPLACEMENT PROCEDURE

1. Remove the fourteen (14) screws of the back-access compartment.

NOTE: The screw heads are Pozidriv and NOT Phillips. Using a Phillips bit could damage the screw heads. Make certain you use a #2 Pozidriv bit.

2. Remove the access compartment panel, and untwist the service loop of both pairs of red/black harness wires.

3. Disconnect the red/black harness wires from the defective woofer.

4. Remove the eight (8) screws holding the woofer in place and remove the woofer.

5. Install the new woofer using the eight (8)

screws.

6. Connect the red/black harness to the speaker terminals. (Red is positive; black is negative.)

7. Perform test procedure to assure the repair is completed.

8. Secure the access compartment with the fourteen (14) screws.

302 CROSSOVER COMPONENT REPLACEMENT

NOTE: Both of the 302 crossover networks supply energy to the 802 speakers. If a 302 is brought in for ANY complaint, each crossover network MUST be tested to assure proper operation of the system. (See Troubleshooting Guide.)

1. Remove the fourteen (14) screws of the back-access compartment.

NOTE: The screw heads are Pozidriv and NOT Phillips. Using a Phillips bit could damage the screw heads. Make certain you use a #2 Pozidriv bit.

2. Remove the access compartment panel, and untwist the service loop of both pairs of red/black harness wires.

3. Replace the defective component.

4. Perform test procedure to assure the repair is completed.

5. Secure the access compartment with the fourteen (14) screws.

302 TROUBLESHOOTING GUIDE	
SYMPTOM	DEFECT
1. NO SOUND:	A. 7-AMP FUSE IS OPEN B. HARNESS WIRE DEFECTIVE C. TWO OPEN VOICE COILS
2. ONE SPEAKER INOPERATIVE:	A. LOOSE SPEAKER TERMINAL B. BAD HARNESS WIRE C. OPEN VOICE COIL IN DEAD SPEAKER
3. NO OUTPUT AT OUTPUT JACK:	A. BAD CROSSOVER COMPONENT B. BAD HARNESS WIRE

302 SCHEMATIC DIAGRAM

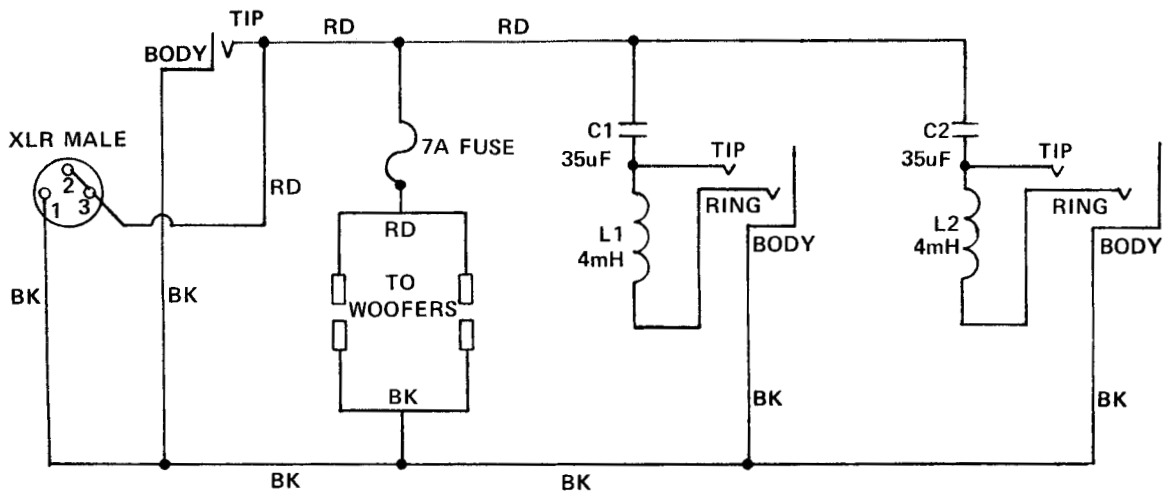

FIG. 16

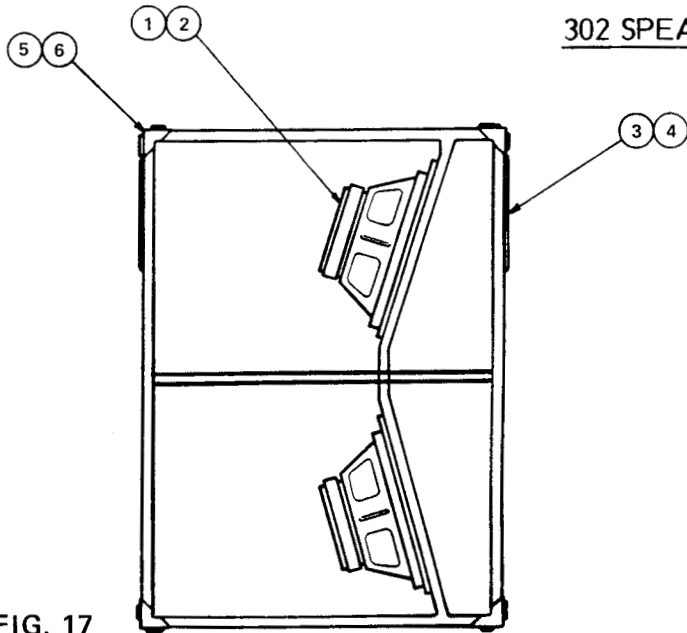

FIG. 17

302 SPEAKER

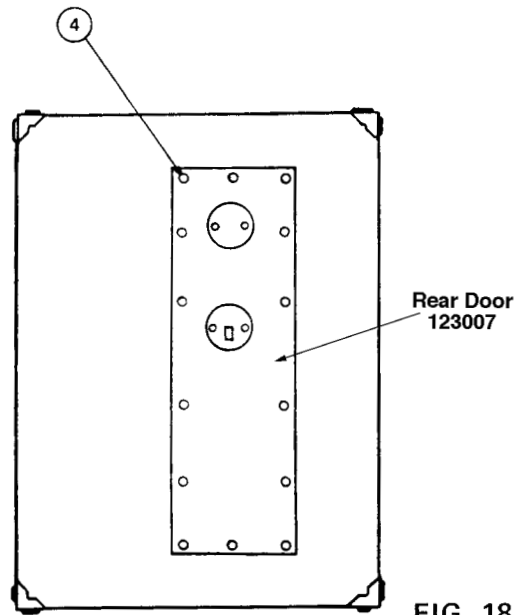

FIG. 18

302 SPEAKER PARTS LIST

<u>Description</u>	<u>Part Number</u>	<u>Description</u>	<u>Part Number</u>
1. 12" Woofer	133131	4. Screw, Pozi Dr	129027-16
2. Screw, 10-24x1 1/4	122869-20	5. Corner, Metal	127018
3. Handle	127443	6. Screw, #6 Pozi Dr	124773-08
Bose® Logo (Not shown)	136069	Nameplate - Acoustimass® (Not shown)	136070

302 INPUT PLATE AND CROSSOVER NETWORK

Crossover Assy.
136244

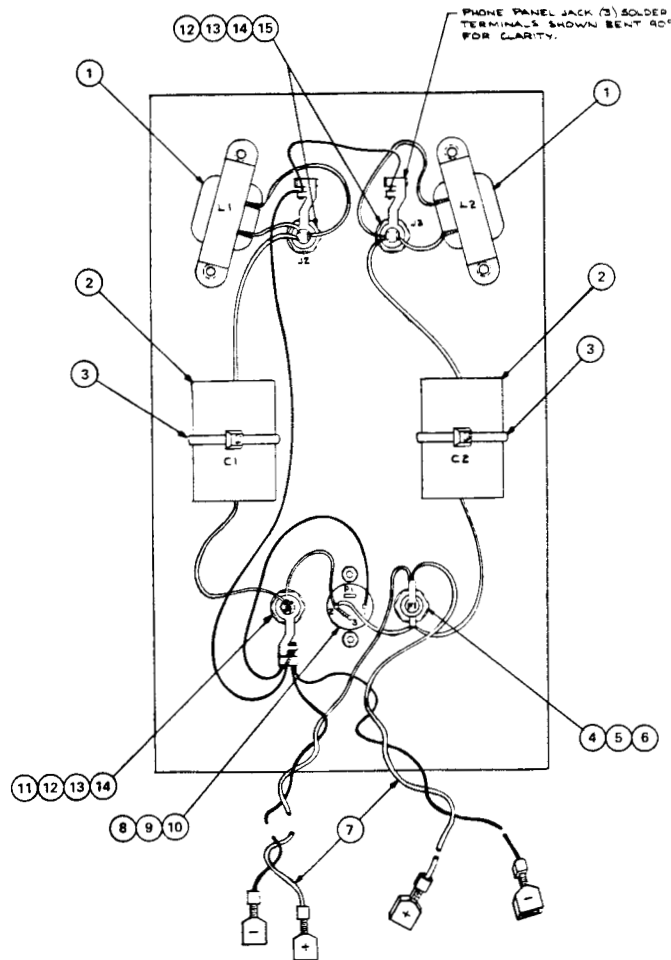

FIG. 19

302 LOUDSPEAKER INPUT PLATE AND CROSSOVER PARTS LIST

Description	Part Number	Description	Part Number
1. Inductor 4 mH	121600	8. Audio Connector	109486
2. Capacitor, 35uf	122749	9. Screw, #4-40	103141-08
3. Tie Wrap	110334	10. Kep Nut #4-40	118260-04
4. Fuse (Preferred)	122862-700	11. Phone Jack 2 Cond	102640
4. Fuse (Alternate)	104715-700	12. Lockwasher, Int	103294
5. Fuse Cap	109484	13. Nut, Hex	100412-14 (part of # 11)
6. Fuse Holder	109485	14. Flat Washer	110999
7. Twisted Pair Assy	121955	15. Phone Jack 3 Cond	121813

302 SPEAKER CARTON KIT

Description	Part Number	Description	Part Number
Filler	123358	Carton	136071
Owner's Manual	136073	Cable, 2' Long	121846-24
Cable, 3' Long	121846-36		

Notes for Future Reference

NOTE: ALL INFORMATION CONCERNING THE 802-C CONTROLLER IN THIS MANUAL PERTAINS TO UNITS WITH SERIAL GROUPING IN THE 100000 RANGE. FOR FURTHER INFORMATION ON THE NEWER SMD VERSIONS (SERIAL NUMBER 2000000 RANGE) REFER TO THE 802-C CONTROLLER SUPPLEMENT: BOSE P/N 129292.

802-C INPUT SENSITIVITY GAIN MODIFICATION

Certain mixer/amplifier models found in Europe have considerably less output than commonly found in the United States. These models have preamplifier outputs typically at .5 volt (500 mV) versus the 1 1/2 to 3 volts and higher found in other areas. To accommodate these lower outputs, we have provided the following 7dB gain modification. This modification should ONLY BE PERFORMED IF the customer's other equipment does have the lower output standards. Modification for use in equipment having higher outputs will cause OVERLOADING of the Controller circuits and associated equipment.

1. Follow Disassembly Procedures for Lower PCB removal.
2. Change resistors R-114 and R-214:
From: 13k To: 28k 1%
3. Locate capacitors C-105 and C-205.
4. Add, in parallel, to each capacitor a 27k 1% resistor.
5. Make notation of modification within the unit for future reference.
6. Follow reassembly procedures.
7. Perform Test Procedures.

NOTE: Output will now be 7dB \pm 1.5dB higher than specifications.

802C SYSTEM CONTROLLER
TEST PROCEDURE

The 802C functions as three equalizers and an electronic crossover network. Depending on jacking configuration, equalization curves and outputs vary. You MUST test all modes of the 802C to assure proper operation.

INITIAL TEST:

Perform the Mode Indicator Test below.

OUTPUT JACKS INSERTED	LED Indicator Status		
	802 Full Range	Passive Bi- 2-Way	AMP
NO JACKS INSERTED	On	Off	Off
TO 802 AMP*	On	Off	Off
TO 302 AMP*	Off	On	Off
TO 802 AMP* AND TO 302 AMP*	Off	Off	On

*ONE OR BOTH JACKS.

FREQUENCY RESPONSE TESTS:

NOTE: Unless otherwise specified, all tests are performed with 750Hz, 500mV input signal. THIS IS THE REFERENCE SIGNAL.

1. 802 Full-Range Jacks: (802 OUTPUTS)

Frequency (Hz)	Response (dB)
750	REFERENCE
30	0 +2.5
55	14.0 +1.5
250	2.7 +1.2
3 K	2.3 +1.5
7.5 K	12.0 +1.5
15 K	16.9 +1.8

2. BOTH Hi-Lo Cut Switches "IN":

Frequency (Hz)	Response (dB)
750	REFERENCE
55	9.8 +1.8
15 K	7.4 +2.0

3. 302 Passive Mode:(302 OUTPUTS ONLY)

Frequency (Hz)	Response (dB)
750	REFERENCE
30	-8.8 +2.5
55	6.2 +1.5
150	-3.2 +1.5
250	3.2 +1.8
3 K	.9 +1.5
15 K	15.3 +1.8

NOTE: For Bi-Amp Modes, you MUST have jacks inserted in BOTH 802 and 302 outputs. Measure where indicated.

4. 302 Bi-Amp Mode:(302 & 802 JACKS)
High Frequency:(Measure at 802 outputs)

Frequency (Hz)	Response (dB)
750 Hz	REFERENCE
55	-20.1 +2.5
230 Hz	2.6 +1.8
15 kHz	17.0 +1.8

Low Frequency:(Measure at 302 Outputs)
INPUT: 100Hz, 500mv REFERENCE VOLTAGE.

Frequency (Hz)	Response (dB)
100	REFERENCE
55	3.7 +1.5
230	-8.3 +1.5
750	-25.8 +2.5

DISTORTION:

Total harmonic distortion MUST be measured in all modes to assure proper operation:

NOTE: Unless otherwise specified, all tests are performed with 750Hz, 5-Volt input signal. THIS IS THE REFERENCE SIGNAL.

1. Full-Range Mode:(802 OUTPUTS)
THD less than .1%

2. Passive Mode:(302 OUTPUTS)
THD less than .3%

3. Bi-Amp Mode:(Measured at 802 Outputs)
THD less than .1%

4. Bi-Amp Mode:(Measured at 302 Outputs)
100 Hz, 5-volt REFERENCE SIGNAL:
THD less than .1%

NOISE:

All noise measurements are ANSI A-weighted true rms, inputs shorted.

1. Full-Range Mode
Less than 20 uV at 802 outputs.

2. Passive Mode
Less than 20 uV 302 outputs

3. Bi-Amp Mode
Less than 10 uV at 302 outputs.
Less than 20 uV at 802 outputs.

802C DISASSEMBLY PROCEDURE

COVER AND TOP PCB REMOVAL:

NOTE: The 802C contains two (2) printed circuit boards, one mounted on top of the other. The top board is for the 302 Output (Passive Mode). This board may be removed for troubleshooting the lower PCB. With the top PCB removed, the 802C will function in the 802 Full-Range Mode. If removal of the top PCB is necessary, follow the steps below.

1. Using a Phillips-head screwdriver, locate and remove the four (4) screws holding the cover in place, and remove the cover.
2. Locate the four (4) plastic stand-offs. (Three are located in a corner of the PCB and the fourth is located between C125 & C225).
3. With small needle-nose pliers, squeeze the retaining tab of each CORNER-MOUNTED stand-off and lift the PCB up slightly from the stand-off to release the lock.
4. Grasp the PCB at the midpoint of each side, and with needle-nose pliers on the fourth stand-off, gently rock the board upward off the connecting pins and out.

NOTE: DO NOT angle the PCB sharply; possible damage could occur to connecting pins.

LOWER PCB REMOVAL:

NOTE: It is not necessary to remove top PCB for lower PCB removal.

1. Locate and remove the five (5) screws holding the PCB in place.
2. Remove the six (6) knurled nuts holding the phone jacks.
3. Looking at the front of each XLR connector, there is a small hole that is not for signal purposes. It is located under the release tab of the connector. Insert a small flat-blade screwdriver (possibly a jeweler's screwdriver), into the small hole, and rotate the screw 1/8 turn counterclockwise. This will release the lock.
4. Angle the PCB out of the XLR connector mount, and lift the PCB out of the chassis.

REASSEMBLY PROCEDURE

LOWER PCB INSTALLATION:

1. Align the lower PCB up with the XLR connectors and the screw mounting posts.
2. Refasten the lower PCB to the chassis with five (5) screws.
3. Looking at the front of each XLR connector, there is a small hole that is not for signal purposes. It is located under the release tab of the connector. Insert a small flat-blade screwdriver (possibly a jeweler's screwdriver), into the small hole, and rotate the screw 1/8 turn clockwise. This will lock the connectors in place.
4. Install the six (6) knurled nuts back on the phone jacks.

TOP PCB INSTALLATION AND COVER:

NOTE: DO NOT angle the PCB sharply; possible damage could occur to connecting pins.

1. Grasp the top board at the midpoint of each side, and align the board to the four (4) stand-offs and connecting pins.
2. Gently lower the PCB down on the connecting pins and stand-offs until the stand-offs are locked in place.
3. Position cover into place and secure with the four (4) screws.

220- To 110-VOLT CONVERSION

NOTE: Conversions must be performed with the line cord disconnected from any power source.

1. Follow the steps in the Disassembly Procedure to remove bottom PCB.
2. Locate jumper LK-31 in front of the power transformer (near the line cord), and remove. (See Fig. 20.)
3. Add jumpers LK-32 and LK-33.
4. Remove 220-volt line cord (if supplied) and replace with 110-volt line cord. Make certain the line cord is properly installed in

the strain relief.

5. Remove 220-volt power tag from back of equalizer cabinet.
6. Perform Reassembly Procedure.
7. Perform Controller Test Procedure.

110- TO 220-VOLT CONVERSION

NOTE: Conversions must be performed with the line cord disconnected from any power source.

NOTE: Conversion is not possible unless 220-volt power transformer and capacitor is ordered from factory. Check parts list. (Line cord is an optional procedure depending on customer needs.)

1. Follow Disassembly Procedure for lower

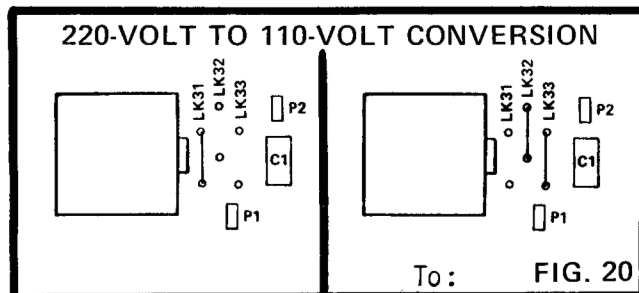

PCB removal.

2. Remove 110-volt power transformer and capacitor C-1, and install 220-volt components. (See 802C parts list.)
3. Add a jumper to LK-31 located in front of the power transformer, near line cord. If LK-32 and LK-33 are installed, remove. (See Fig. 21.)
4. Remove 110-volt line cord (if necessary), and replace with 220-volt line cord. Make certain the line cord is properly installed in the strain relief.
5. Add a 220-volt label to back of equalizer cabinet.
6. Perform Reassembly Procedure.
7. Perform Controller Test Procedure.

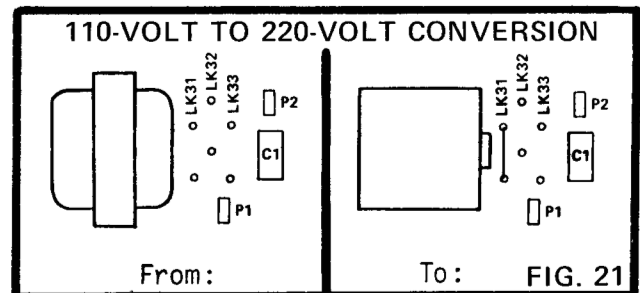

Rack Mount Kit 802C ACCESSORIES

FIG. 22

RACK MOUNT KIT PARTS LIST

Description	Part Number
Rack Mount Kit	121771
Panel	121859
Mounting Bracket	109643
Screw-Sh Met #4 x .25L	103118-04
Hex Nut/Washer #8-32	100413-2
Screw-Truss Hd 10-32x.5L	111200-08
Instruction Sheet	121861
Carton	110339

802C TRANSIT KIT

FIG. 23

Description	Part Number
Transit Kit	123037
Loopstrap	109472
Bracket	109473
Hook	109474
Screw #8	108229-08
Cord Clip	111381
Instruction Sheet	122780

802C SYSTEM CONTROLLER PARTS LIST

NOTE: All information concerning the 802-C Controller in this manual pertains to unit with serial grouping in the 100000 range. For further information on the newer SMD versions (serial number 2000000 range) refer to the 802-C Controller Supplement; Bose P/N 129292.

SEMICONDUCTORS

DIODES

<u>Symbol</u>	<u>Description</u>	<u>Part Number</u>
D1,101-104,201-204	Diode 1N4148	121501
D2-4	LED	123487
Z1	Bridge Rectifier	112027

TRANSISTORS

Q1,4,5	Transistor (NPN)	117921
Q2,3,6	Transistor (PNP)	119168

IC'S

U1,8,9	Op Amp-Quad (LS-404)	120535
U2	Regulator (78L15)	121116-1
U3	Regulator (79L15)	121117-1
U4	IC Quad Nand (CD4011)	121854
U5,6	Op Amp-Quad (RC4156)	123458*
U7,10	Quad AW.SW. (CD4066)	119837

*NOTE: RC-4156 is to be used ONLY as a replacement for U5 and U6. This replaces the SELECTED LS-404 IC previously used in these locations. Due to higher current needs of the RC-4156, if used in other areas, damage could occur to the power supply of the 802C.

CAPACITORS

<u>Symbol</u>	<u>Description</u>	<u>Part Number</u>
C2,3	Film, .015 uF	118091-153
C4	Cer Disc .01 uF	119626-103
C5,6	Elctlc, 470 uF	110704
C7-10	Elctlc, 1 uF	119942-1R0
C11-18	Cer Disc .1 uF	117502
C19,22	Cer Disc .1 uf	117502
C101,117,C201,217	Elctlc, 22 uF	119944-220
C102,202	Elctlc,2.2 uF 50V	119943-2R2
C103-105,203-205	Film, .0068 uF	118091-682
C106,206	Film, .33 uF	123785-334
C107,108,207,208	Film, .1 uF	118091-104
C109, 209	Film, .0012 uF	118091-122
C110,126,127,210,226,227	Cer Disc 470 pF 10%	119617-471
C111,211	Cer Disc 270 pF 10%	119617-271
C112,113,212,213	Film, .033 uF	118091-333
C114,214	Film, .068 uF	118091-683
C115,116,215,216	Film, .047 uF	118091-473
C118,119,218,219	Film, .082 uf	118091-823
C120,220	Film, .022 uf	118091-223
C121,122,221,222,	Film, .1 uf	118091-104
C123,223	Film, .047 uf	118091-473
C124,224	Film, .033 uf	118091-333
C125,225	Elctlc, 22 uf	119944-220

RESISTORS

Unless otherwise specified, all resistors are 1/4 watt.

<u>Symbol</u>	<u>Description</u>	<u>Part Number</u>
R1,2	2.7K 5%	117704-1212725
R3,4	3.3K 5%	117704-1213325
R5,6,7,11,15,118,218	160K 5%	117704-1211645
R8,9,12,13,16,17,	330K 5%	117704-1213345
R101,201,104,204		
R10,14,18	8.2K .50W 5%	122071-8225
R102,103,105,122,124,	2.00K 1%	119976-2212001
R202,203,205,222,224		
R106,206	1.91K 1%	119976-2211911
R107,207	48.7K 1%	119976-2214872
R108,208	20K 5%	117704-1212035
R110,210	2.74K 1%	119976-2212741
R111,113,211,213	1K 5%	117704-1211025
R112,212	4.75K 1%	119976-2214751
R114,214	13K 2%	117704-1211332

RESISTORS

Unless otherwise specified, all resistors are 1/4 watt.

<u>Symbol</u>	<u>Description</u>	<u>Part Number</u>
R115,215	10K 5%	117704-1211035
R116,125,216,225	8.2K 2%	117704-1218222
R117,128,129,133,134, R217,228,229,233,234	6.81K 1%	119976-2216811
R119,120,219,220	18K 5%	117704-1211835
R121,136,221,236	22K 5%	117704-1212235
R123,223	470 5%	117704-1214715
R127,227	130K 5%	117704-1211345
R109,126,130,131, R209,226,230,231	23.7K 1%	119976-2212372
R132,232	6.04K 1%	119976-2216041
R135,159,235,259	510 ohm .5 Watt, 5%	122071-5115
R137,237	47.5K 1%	119976-1214752
R138,140,238,240	15.0K 1%	119976-2211502
R139,151,239,251	8.2K 2%	117704-1218222
R141,145,147,153-158, R241,245,247,253-258	6.04K 1%	119976-2216041
R142,242	3.01k 1%	119976-2213011
R143,243	33K 5%	117704-1213335
R144,244	56K 2%	117704-1215632
R146,152,246,252	4.75k 1%	119976-2214751
R148,248	4.12K 1%	119976-2214121
R149,249	23.7K 1%	119976-2212372
R150,250	30.9K 1%	119976-2213092
R160,260	22K 5%	117704-1212235

COSMETIC

<u>Symbol</u>	<u>Description</u>	<u>Part Number</u>
	Chassis	133230
	Cover	135040
	Strain Relief Bushing	106346
	Carton	121789
	Accessory Kit	121783

MISCELLANEOUS

<u>Symbol</u>	<u>Description</u>	<u>Part Number</u>
S1,2	Dual Switch	107461
	Knob, Switch	120989
	Switch Sleeve	120996
	Insulator 1	122855
J1,3	Connector XLR Insert	121823
	XLR Connector	121810
J2,4-8	Phone Jack	121570
	Knurled Nut	121890
J9	Wafer, 7 Pin (2461)	123237-07
J9	Connector, 7 PIN (2145B)	121970-07
J10	Wafer, 6 Pin (2461)	123237-06
J10	Connector, 6 PIN (2145B)	121970-06
Machine Screw	#4-40 x .187L	103140-03
	Led Bracket	120975
P1,2	Terminal Faston	111262
Screw	Sh Met #4-40 x .25L	103118-04
Sleeving, 20 AWG	D2-4	107679-20
	Stand Off	123199
	Bumper (Feet)	103593

VOLTAGE COMPONENT VARIATIONS

<u>Symbol</u>	<u>Description</u>	<u>Part Number</u>
T1	Transformer (110/220V)	120993
T1	Transformer (120V)	121659
T1	Transformer (100V)	121824
C1 (Line) Cap Myler	.0047uf DW/LINE(220V)	111715
C1 (Line) Cap Disc	.0047uf 1.4 KV(100,120V)	103447
Line Cord	115/100V	111672
Line Cord	220V	113608
Silicon Rubber(RTV)	220V T1 Primary Sealant	120793
Screw, Mach Ny 6-32x.75L	220V	124843-12
Screw, Mach Ny 6-32x.25L	220V	128843-04
Standoff, Hex #6x.375L	220V	121828-06

Bose® WB-2 Wall Bracket

The WB-2 Wall Bracket is a versatile hinge-and-chain system designed for fast, secure mounting of Bose 802-W and 402-W Loudspeakers with up to 60° of adjustment in 3 axes.

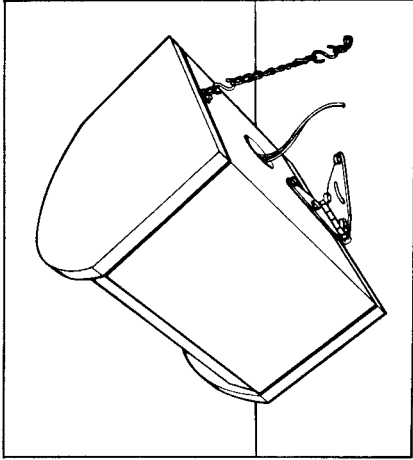

802-W Loudspeaker, side wall mount.

FIG. 24

Description	Part #
Hinge Segments	119270
4-foot Twist-Link Chain	120079-2
Hinge Bolt	119269
Hex Stop Nut	119801
D-Rings	120093
S-Hooks	119797
8 mm Bolts	119798
8 mm Threaded Inserts	119767
Flat Washers	119799
Spring Washers	119800

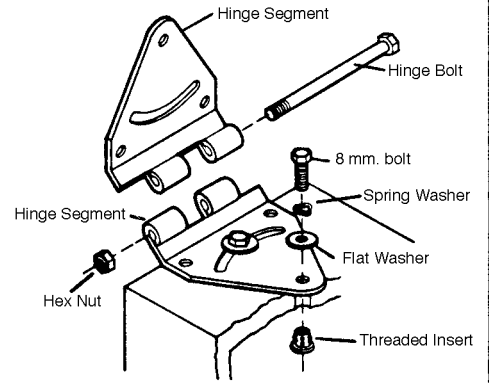

FIG. 25

SS-5 SPEAKER STAND

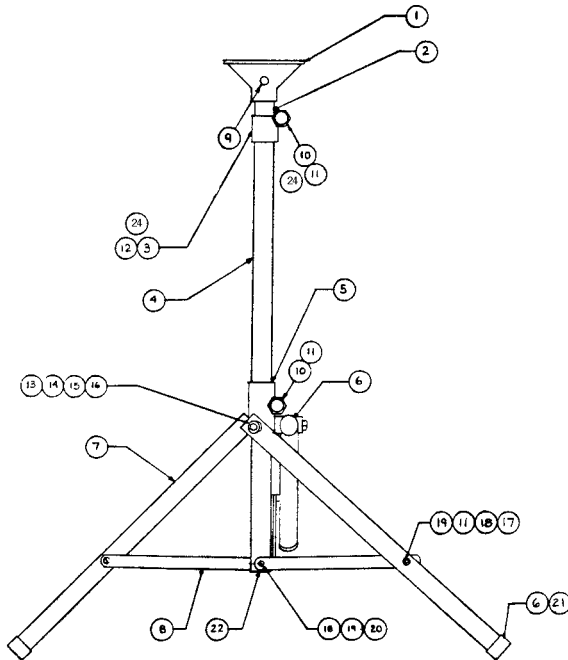

FIG. 26

ITEM	DESCRIPTION	BOSE P/N
1	Base Mount	121526
2	Upper tube U-2	121212
3	Collar TC-2	121213
4	Lower Tube U-1	121214
5	Leg Fitting TL-12	121215
6	Compression Plug CP-112	121216
7	Leg U-3	121217
8	Brace ULB-1	121218
9	Thumb Screw K8T-144N	121219
10	Hand Knob HK-4	121220
11	Nylon Washer NW-144	121221
12	¼-20x1" Soc Jd Cap Sc	121222
13	5/16-18x2 ¼Hex Hd Bl	121223
14	5/16 Fender Washer	121224
15	Saddle Outside SL312	121225
16	Saddle Inside SL375	121226
17	¼-20x2 ¼ Scw Flat Hd	121227
18	Stand Off 50-250	121228
19	¼-20 Mylock Nut	121229
20	¼-20x1" Flat Hd Scw	121230
21	Foot Cap MD-20-1000	121231
22	1½ End Cap EC-148	121232
23	Nylon Tote Bag	121235
24	1/4-20 Nut	136786

Notes for Future Reference

SPECIFICATIONS AND FEATURES SUBJECT TO CHANGE WITHOUT NOTICE

BOSE®
better sound through research™

Bose Corporation
The Mountain
Framingham, Massachusetts USA 01701